



# Installation, Operation & Safety Manual

**Product:** Stainless Steel Manual Jackplate

**Offsets:** 100 mm (4") / 150 mm (6")

**Max Engine Power:** 200 HP

**Max Load:** 250 kg

**Made in the European Union**

**Compliance:** Machinery Directive 2006/42/EC & EN ISO 12100:2010



# 1. Technical Specifications

- **Material:** 5mm Stainless Steel AISI 304 frame (316 optional).
- **Offset (Setback):** 100mm (4") and 150mm (6")
- **Maximum Engine Power:** Up to 200 HP outboard engines.
- **Maximum Outboard Weight:** Up to 250 kg.
- **Corrosion Protection:** Pre-installed replaceable sacrificial anode.
- **Lifting Mechanism:** Mechanical, manually operated lifting assembly.
- **Total Lift Range:** 140mm (Static lift: 40mm + Adjustable lift: 100mm).

---

## 2. Component Checklist & Hardware Stack

The Jackplate's proper functioning relies on specific assembly order. Although the jackplate comes pre-assembled from the factory, the assembly stacks must be arranged as shown below:

### 2.1. Side Clamps Assembly

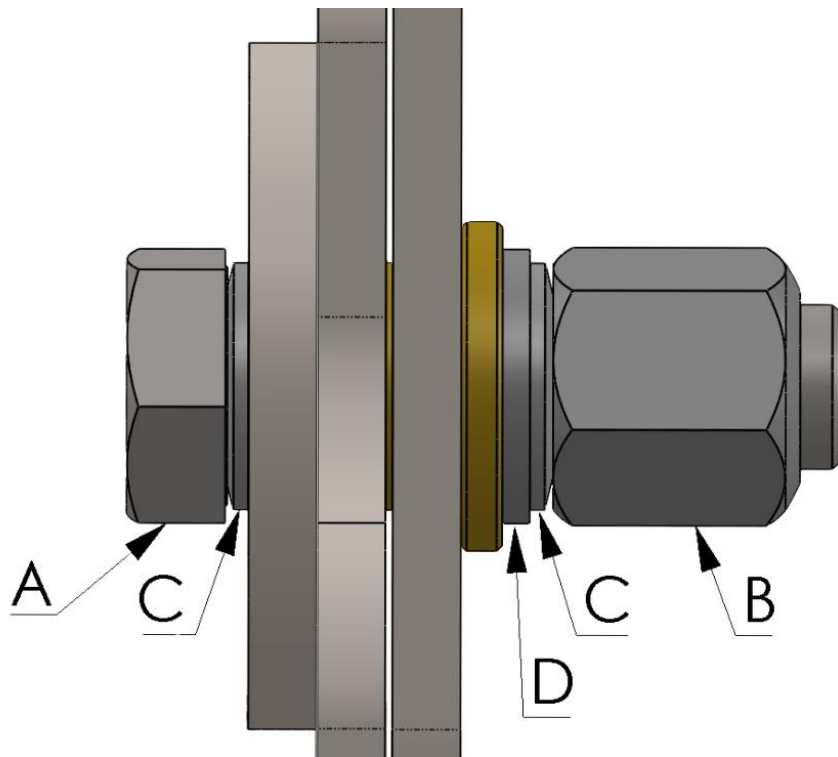

- **A: M12 A4-70 (M12x45) Clamping Bolts (4x).**
- **B: M12 A4-70 Long Nuts (Coupling Nuts) (8x).**
- **C: Schnorr Safety Washers (8x).**
- **D: A4 Stainless Flat Washers (Load Spreaders) (4x).**

**WARNING:** Observe the conical shape of the **Schnorr Safety Washer (C)**. Each of the four **Clamping Bolts (A)** uses two **Schnorr washers (C)**. They must be installed with the "high side" (the inner diameter of the cone) facing the **Bolt Head (A)** and the **Nut (B)**. This ensures the washer acts as a live spring to maintain bolt tension under engine vibration.

**WARNING:** Always install the **Flat A4 Washer (D)** between the **Schnorr Washer (C)** and the **Bushing**. This protects the softer bushing metal from the hardened locking teeth of the **Schnorr washers (C)**.

---

## 2.2. Outboard Mounting Assembly

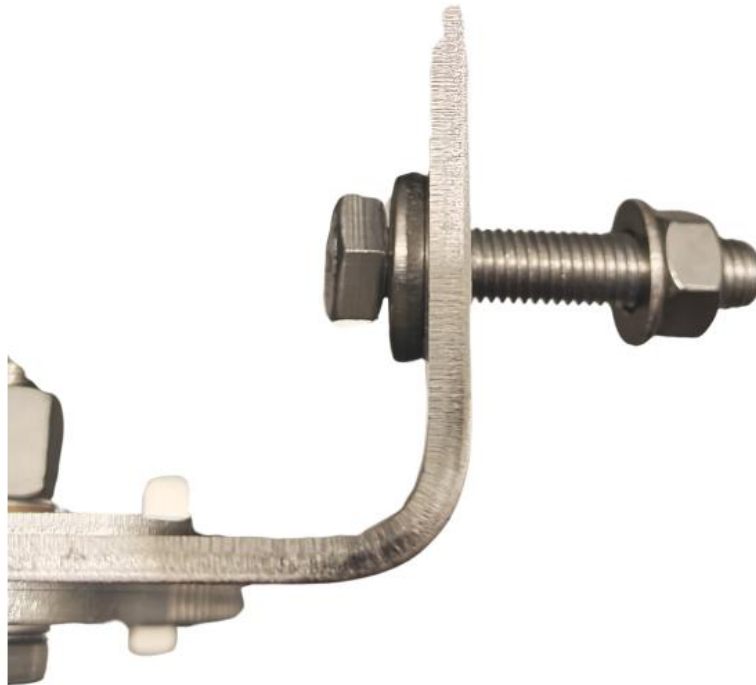

**WARNING:** The **Heavy-Duty Thick Washer** must be placed on the **inside**, directly against the Jackplate's stainless steel faceplate. This washer acts as a structural load spreader to handle the thrust and weight of high-horsepower engines. The **Standard Thickness Washer** sits beneath the nut on the engine bracket side.

### 3. Mounting Instructions

#### Step 1: Transom Preparation

- Ensure the boat transom is free of oil, grease, and debris.
- **WARNING:** Apply a semi-permanent marine sealant (e.g., **Sikaflex 291i** or **3M 4200**) to the face of the plate toward the transom (shaded areas in the diagram) and on the bolt threads / holes and the washers inside the transom. This provides protection against water ingress.

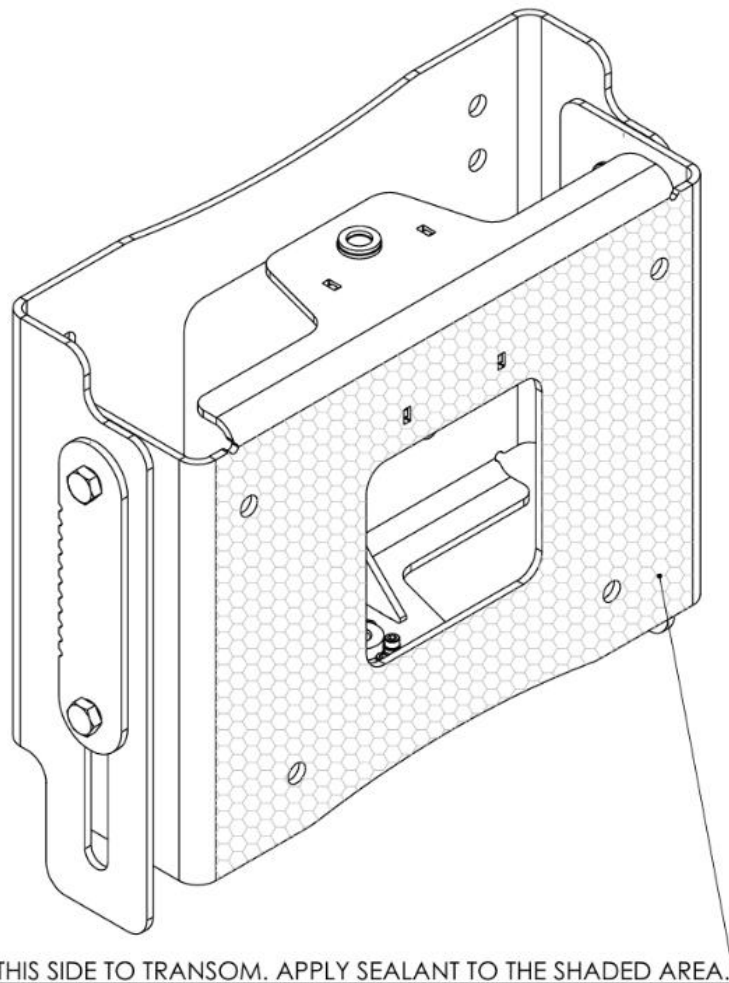

#### Step 2: Mount to Transom

- Secure the Jackplate to the transom using the **mounting hardware provided by your outboard manufacturer.**
- Tighten to **specs according to your transom type and boat's manufacturer.**

### Step 3: Mount Outboard to Jack Plate

- Lower the plate to its lowest position.
  - Mount the outboard using the hardware **included with the Jackplate** (shown on fig. 2.2)
  - Tighten to **the specs provided by your Outboard manufacturer**.
- 

## 4. Height Adjustment and Setup Optimization



1. **Loosen** the 4 side clamping bolts.
2. **Rotate** the M14 Trapezoidal Spindle at the top to set the desired height. **Start with 1 inch above your previous setup (before mounting a Jackplate).**
3. **Verify** alignment using the **10 mm indents**.
4. Once the height is set, tighten the 4 side clamping bolts to **75 Nm**.
5. **Test your setup on water**. Test the setup on water. The propeller must not cavitate at wide open throttle (WOT). If cavitation occurs, reduce engine height. If no cavitation is observed, the engine height can be increased further to reduce drag and improve RPM, acceleration, and top speed.
6. Optional: Apply thread locker (e.g., Loctite 243) to the side clamp bolts for additional security.

**WARNING:** Never operate the lifting bolt while the side clamping bolts are fully tightened.

## 5. Anode Protection (Sacrificial Anodes)



The Jackplate is equipped with a pre-installed sacrificial anode to protect both the stainless steel frame and your outboard's aluminum components from galvanic corrosion.

- **Inspection:** Check the condition of the anode every 6 months.
- **Replacement:** Replace the anode immediately once it has reached **50% of its original size**.
- **Direct Contact:** The anode must have direct metal-to-metal contact with the stainless steel. **Never** paint over the anode or apply sealant between the anode and the plate.
- **Water Type:** Ensure you use the correct replacement material for your environment.

## 6. Safety & Maintenance

- **Clearance Check:** Fully trim the outboard to ensure the hydraulic steering rod clears the Jack Plate flanges.
- **Vibration Check:** Retighten all bolts after the first 5 hours of use and periodically thereafter.
- **Lubrication:** Periodically apply marine grease to the A4 stainless steel M14 trapezoidal screw and bronze nut.

## 7. Warranty & Liability

This product is covered by a 24-month limited warranty against manufacturing defects.

The warranty does not cover:

- Improper installation
- Incorrect torque or mounting
- Use beyond specified load or engine limits
- Corrosion caused by lack of maintenance or anode neglect

The manufacturer is not liable for damage resulting from improper installation or misuse of the product.

Always follow installation instructions and safety guidelines.

---

## 8. Support

For technical support, installation questions, or replacement parts:

Email: [info@donmarine.eu](mailto:info@donmarine.eu)

Website: <https://donmarine.eu>

Response time: within 24 hours (EU business days)